

220(L)*94.5(W)*40(H) mm

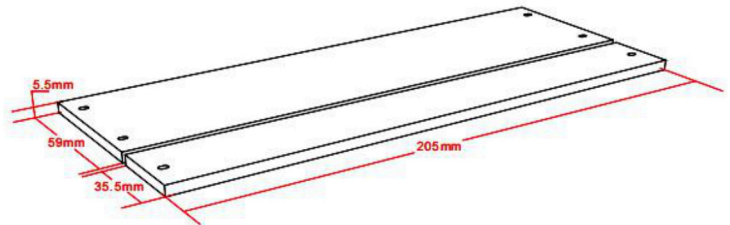

FEATURES

- Output constant voltage
- Range 100-305VAC, Typical: 100-277VAC
- UL, cUL listed, Class 2 unit, Type HL rated. FCC
- Built-in PFC function / PF>0.99
- High efficiency > 86% / Dimming range: 0~100% / Load: 10-100%
- Protections: short circuit / over voltage / over heat
- PWM output, does not change the color index
- Full protection aluminum housing, for dry, damp and wet location
- Cooling by free air convection
- Strong compatibility, flicker-free dimming, PWM output
- Suitable for LED lighting and moving sign applications
- Compliance to worldwide safety regulations for lightings.
- 0-10V dimming: 0-10V / 1-10V / Potentiometer / 10V PWM 4 in 1
- Phase dimming: work with forward phase / leading edge, MLV and reverse phase / trailing edge, ELV, TRIAC dimmers

TECHNICAL SPECIFICATIONS

Model		LCPSL CODIM010V-24V-96W
Output	DC Voltage	24V
	Voltage Tolerance	±0.5V
	Voltage Regulation	±0.5%
	Load Regulation	±1%
	Rated Current	4.0A
	Rated Power	96W (class 2)
Input	Voltage Range	100-277VAC
	Frequency Range	47 ~ 63HZ
	Power Factor (Typ.)@full load	0.98@120VAC 0.95@277VAC
	THD(Typ.)@full load	<20%
	Inrush Current(Typ.)	20A, 50%, 1.6ms
	Efficiency(Typ.)@Full Load	83%@120VAC 86%@277VAC
	AC Current (Typ.)	1.3A @100VAC
	Leakage current	<0.50mA
Protection	Short Circuit	shut down o/p voltage, re-power on to recover after fault condition is removed
	Over load	≤120% constant current limiting, auto-recovery
	Over temperature	100°C±10°C shut down o/p voltage, automatically recover after cooling
Environment	Working temp.	-40 ~ +60°C
	Working Humidity	20 ~ 90%RH, non-condensing
	Storage TEM., Humidity	-40 ~ +80°C, 10 ~ 95%RH
	Temp. coefficient	±0.03%/°C (0 ~ 50°C)
	Vibration	10 ~ 500Hz 2G 10min./1 cycle, period for 60min.each along X,Y,Z axes
Safety & EMC	Safety standards	UL8750+UL1310
	Withstand voltage	I/P-O/P: 1.88KVAC
	Isolation resistance	I/P-O/P: 100MΩ/500VDC/25°C/70%RH
	EMC EMISSION	FCC Part 15 B
Others	Weight	1.3Kg
Notes	<p>1. All parameters NOT specially mentioned are measured at 120VAC input, rated load and 25°C of ambient temperature</p> <p>2. To extend the driver's lifespan, reduce the loading at lower input voltage.</p>	

- Connect the black and white input wires to the AC L (live) and N (neutral) respectively, and the green wire to the ground.
- For the output wires, connect the red wire to the positive side (+) of the LED and the black wire to the negative side (-) of the LED.
- Connect the purple DIM (+) cable to the positive (+) terminal of the 0/1-10V dimmer signal, and the grey DIM (-) cable to the negative (-) terminal of the 0/1-10V dimmer signal.
- It is crucial to ensure these connections are made correctly to prevent malfunction and potential damage to the product.

CONNECTING DIAGRAM

Using TRIAC/Phase cut dimming

1. The Pulse-Width Modulation (PWM) of the output voltage can be adjusted through the input terminal of the AC phase line (L) by connecting to a phase/Triac dimmer of the lighting system.
2. Compatible with forward phase/leading edge (MLV) and reverse phase/trailing edge (ELV, TRIAC) dimmers.
3. Please ensure to use dimmers with a power rating at least 1.5 times greater than the output power of the driver.

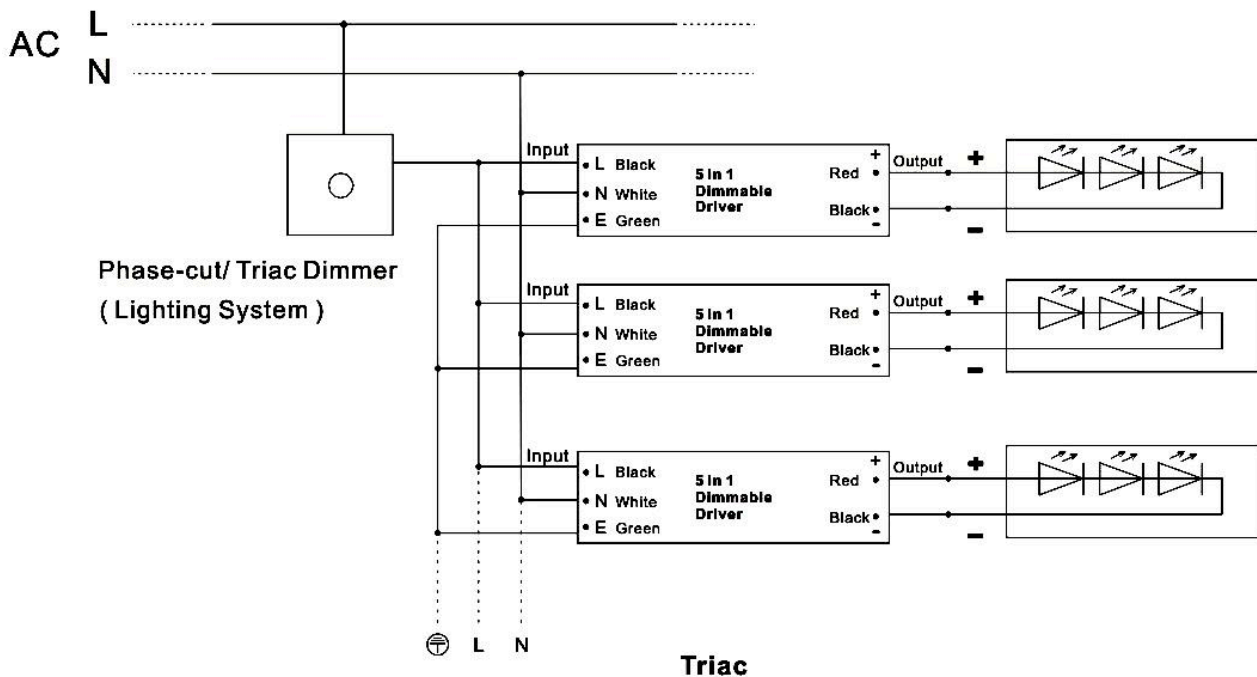

Using 0-10/1-10V dimming

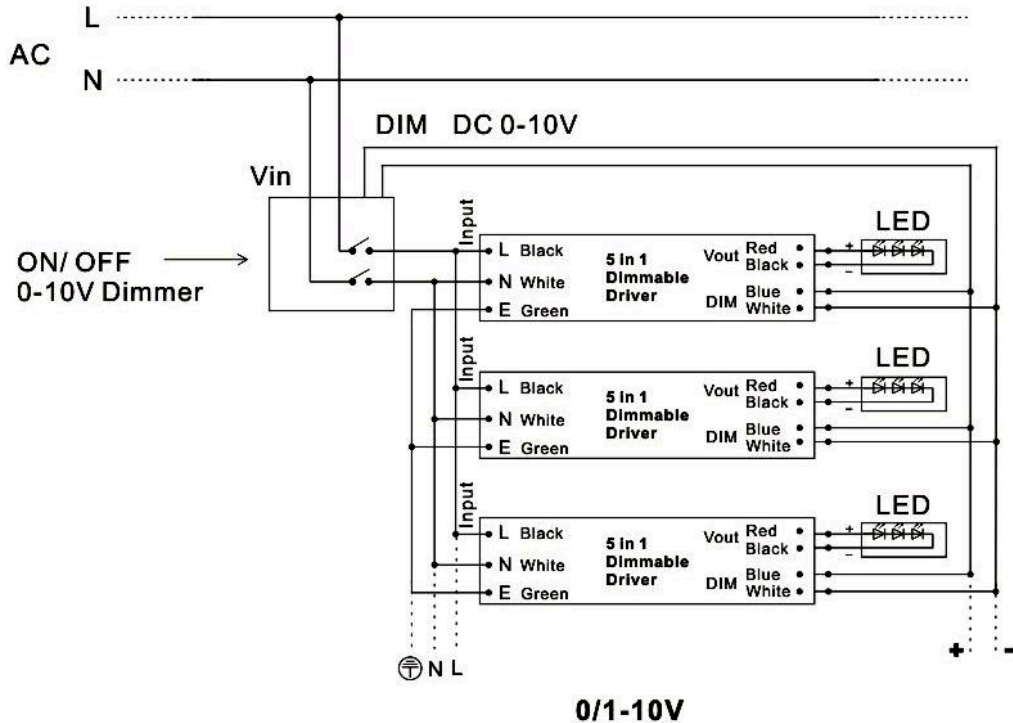
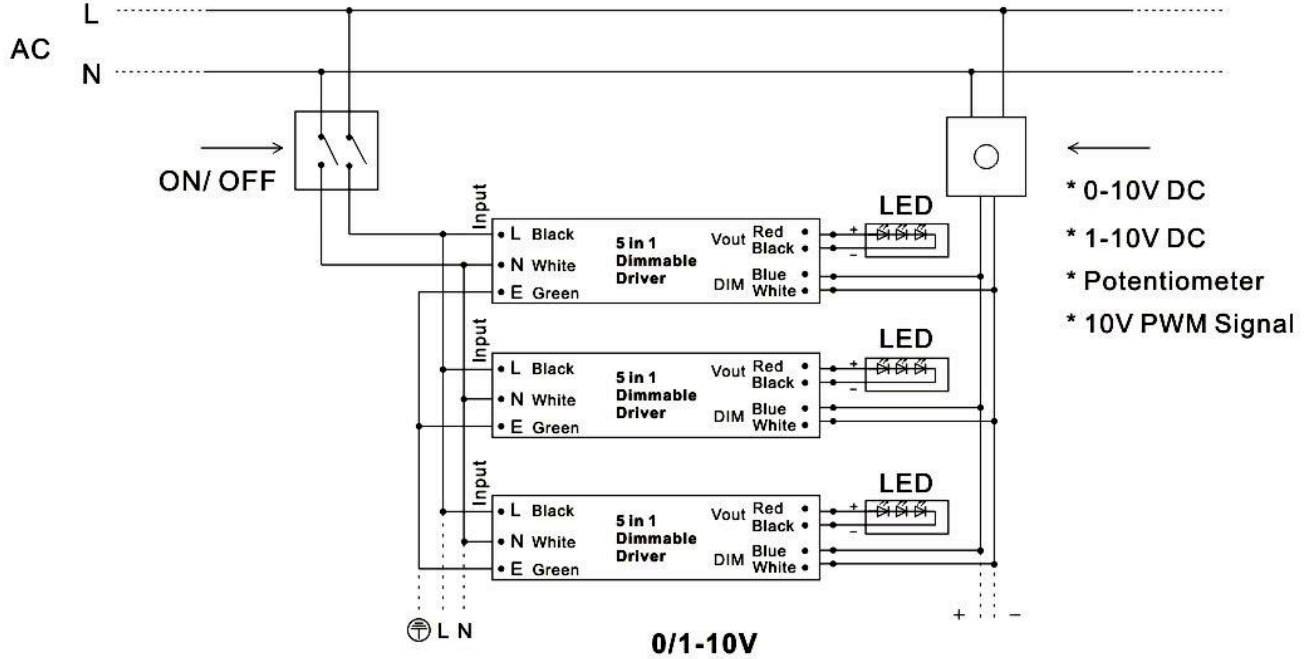

DERATING CURVE

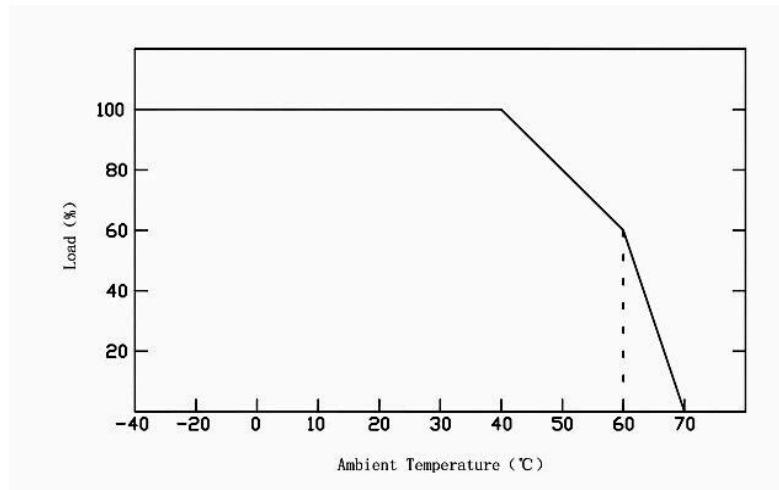

Make sure to adjust the load based on the load derating curve, which accounts for changes in ambient temperature. This helps prolong the working life of the system.

INSTRUCTION

- This driver should be installed by qualified and professional person;
- Please make sure the driver is installed with adequate ventilation around it to allow for heat dissipation.
- Ensure that wiring is correct before test in order to avoid light and power supply damage;